



## Description

The HWS14 is optimized for highly accurate measurement of very low air velocity in laminar flow control and special ventilation applications, for instance in clean rooms. HWS14 series provides current, voltage signal or RS485 output. In addition, HWS has LCD display and models with independent sensor probe.

## Feature

- Multiple output signals are optional.
- Linear compensation and temperature compensation, improve the accuracy and resolution.
- Good stability.
- Measured faster and more accurately.
- Multiple input ranges are optional.

## Applications

- HVAC.
- Filter pressure drop monitoring.
- Flue gas treatment.
- Textile, chemical, aviation, power plant, coal mine application.
- Pipeline air flow.
- VAV system.
- Biosafety cabinet.
- Operating room, purification room, biological laboratory, electronic medical environment and other fields.
- Slightest breeze velocity measurement.



## Technical data

### Input

Working range	0-1m/s, 0-2m/s, 0-5m/s, 0-10m/s, 0-15m/s, 0-20m/s, 0-30m/s, 0-40m/s, 0-50m/s
Accuracy	0.2%fs
Resolution	0.05m/s
Response time	0.2 sec at constant temperature

### Output

Output signal	0-10Vdc, 4-20mA, 0-5Vdc, RS485
Protocol	Modbus RTU
Display type	LCD module

### Supply

Power supply	24Vac/dc or 12Vac/dc $\pm$ 20%
Frequency	50Hz
Current consumption	170mA(AC supply) or 70mA(DC supply)

### General

Cable gland	M16x1.5
Electromagnetic compatibility	EN61326-1, EN61326-2-3
Enclosure material	Polymer resin, RoHS Certification
Protection class	Enclosure IP65, remote probe IP20
Installation	Duct / remote, flange
Storage temperature	-10 - +80°C
Working environment temperature	-5 - +70°C
Humidity	Not condensation from 0-90%RH
Length of probe	220mm standard
Electrical connection	Screw terminals max. 1.5 mm <sup>2</sup>
Chipset	Ceramic hot film sensor
Installation	Flange installation
Cable length	BVVR 0.5mm <sup>2</sup> allow 70m, BVVR 1mm <sup>2</sup> allow 200m, BVVR 1.5mm <sup>2</sup> allow 300m

### Analogue output

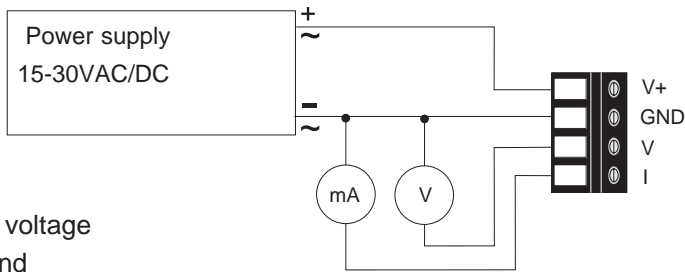

V+ = supply voltage  
 GND = ground  
 V = voltage output (RS485 A)  
 I = current output (RS485 B)

### Structure and dimension

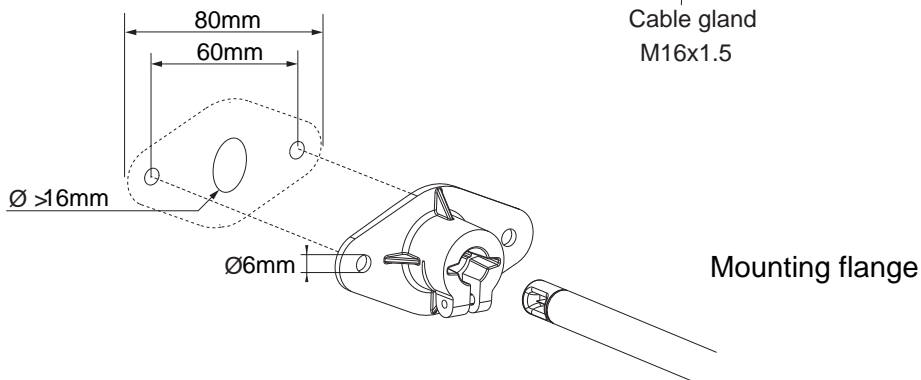
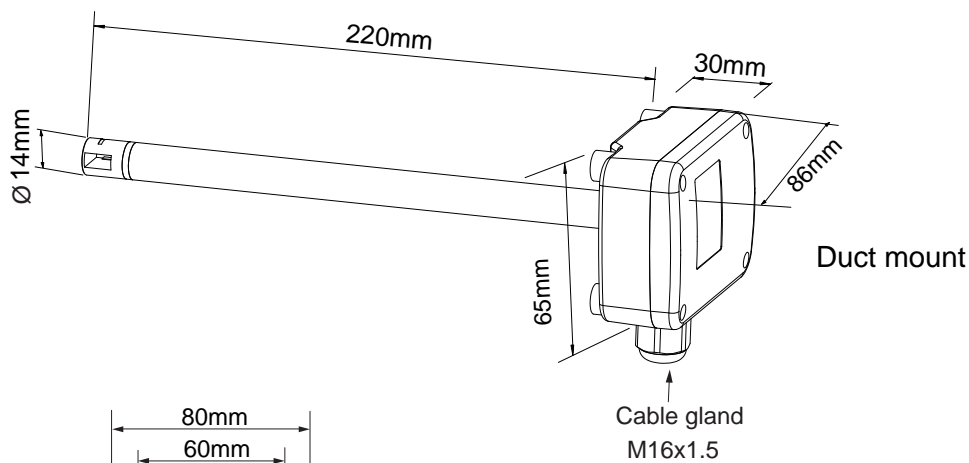
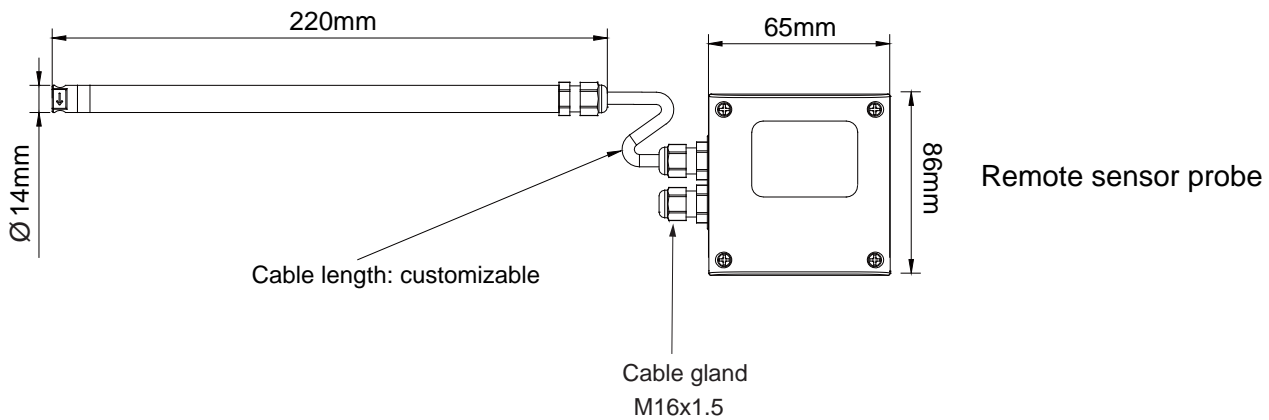

## Mounting

Drilling in the wall of the duct for installing the mounting flange.

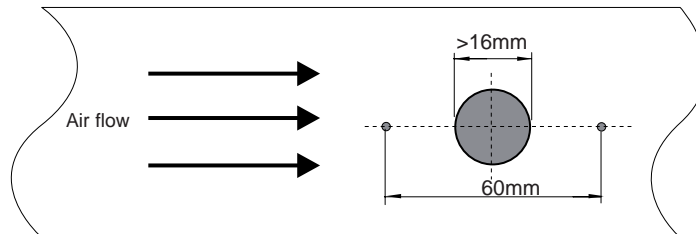

The arrow engraved on the sensing head of HWS indicates the direction of the air stream during factory adjustment. When installing the HWS probe, make sure that the arrow matches exactly the flow direction.

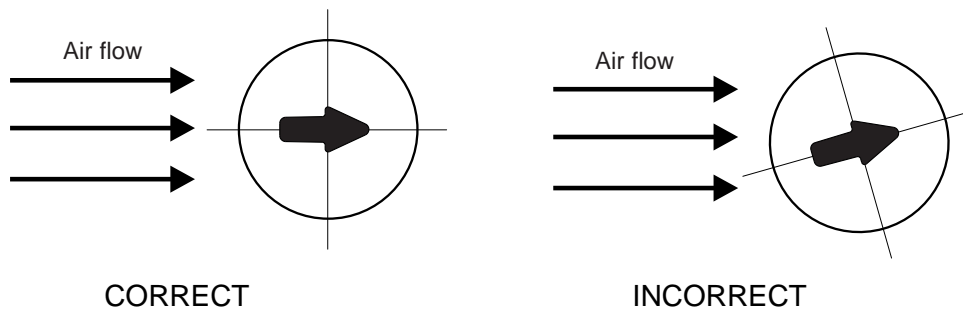

The mounting flange allows for precise setting of the HWS immersion depth in a duct. The entire sensing head must be in the air flow to be measured.

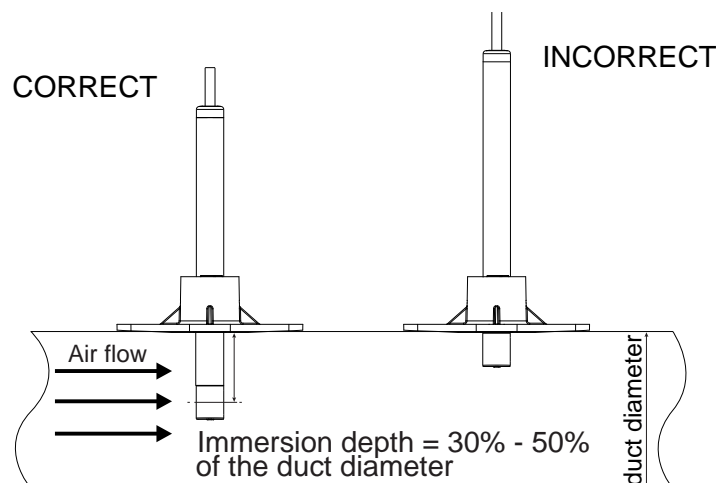



## Model description

